

## SUPPLEMENTAL INFORMATION

### STONE FURNITURE / STONE FURNITURE AND TOPS

#### SECTION 1. INTRODUCTION

**1.01 Installation Methods.** There are several methods by which stone furniture can be fabricated and installed. Consideration should be given to the various features of each method. Refer to recommendations furnished by MIA Members specializing in furniture and top construction. See information about installation methods in this section's Data Sheet, Part 3, and illustrations of examples at the close of this section.

#### SECTION 2. DESIGN CRITERIA

**2.01 Sealings.** Furniture or tops may be sealed or unsealed depending upon location and conditions of usage.

1. If sealed, follow Manufacturer's re-commendations for cleaning, stripping, and resealing.
2. If tops are used for food preparation, make certain sealer applied is nontoxic and safe for food preparation areas.

**2.02 Base Design.** Adequate support of stone should be designed into the base to prevent accidents and fracturing of the stone after assembly or installation.

**2.03 Unsupported Spans And Overhangs.** The size of any unsupported span or overhang depends upon the thickness and type of stone used.

1. It is not recommended to project any unsupported stone past the base more than 6", for stone of 3/4" or less thickness.
2. When using some of the more fragile stones, including Soundness Classification Groups C and D marbles, the use of an unsupported stone overhang of any dimension may not be feasible.
3. Stone thicker than 3/4" can have a greater unsupported span.
4. Overhangs can be increased if other stone, such as Soundness Classification Group A marble, slate, or travertine, 3/4" thick exterior plywood, or other structural support is provided for the finished stone.

**2.04 Exposed stone edges** must be gauged to the precise thickness specified. Gauging tolerance cannot be over  $\pm 1/32"$ .

**2.05 Dimensions of bevel and quirk miters** and radius of rounded edges should be specified.

**2.06 Laminated Aprons.** When fabricating laminated aprons and double thicknesses, all jointed edges and horizontal surfaces must be sanded or ground to eliminate irregularities and ensure 100% contact.

**2.07 Oil-based putty and sealants** cannot be used in contact with stone.

*For additional information, refer to Chapter 13, Installation General Information and Chapter 17 Residential Countertops.*

**2.08 Geographic Methods.** Some installation methods and materials are not recognized and may not be suitable in some geographic areas because of local trade practices, building codes, climatic conditions, or construction methods. Therefore, while every effort has been made to produce accurate guidelines, they should be used only with the independent approval of technically qualified persons.

#### SECTION 3. PRODUCT DESCRIPTION

**3.01 Basic Use.** Furniture and tops.

**3.02 Fabrication.** Stone furniture and tops are precut and prefinished to dimensions specified on shop drawings, and are delivered to the job site ready to install or place in a predetermined location.

**3.03 Finishes.** Polished, honed, natural cleft, and rough.

**3.04 Colors.** Most of the commercially available varieties are suitable.

**3.05 Sizes.** Custom according to design requirements and size limitations of selected stone.

#### SECTION 4. TECHNICAL DATA

4.01 Each stone variety used for stone furniture and tops should conform to the applicable ASTM standard specification and the physical requirements contained therein.

4.02 These specifications are as follows:

1. **Granite:** ASTM C615 Standard Specification for Granite Dimension Stone

#### SECTION 5. INSTALLATION

**5.01 Methods.** Furniture is usually pre-assembled in the Fabricator's shop.

1. Tops are anchored to the supporting base with dowels, pins, nonstaining adhesive, or a combination of these.

**5.02 General Precautions:** During construction, the General Contractor shall protect all stone from staining or damage.

1. Oil-based putty and sealants should never be used in contact with stone.

# SUPPLEMENTAL INFORMATION STONE FURNITURE / STONE FURNITURE AND TOPS

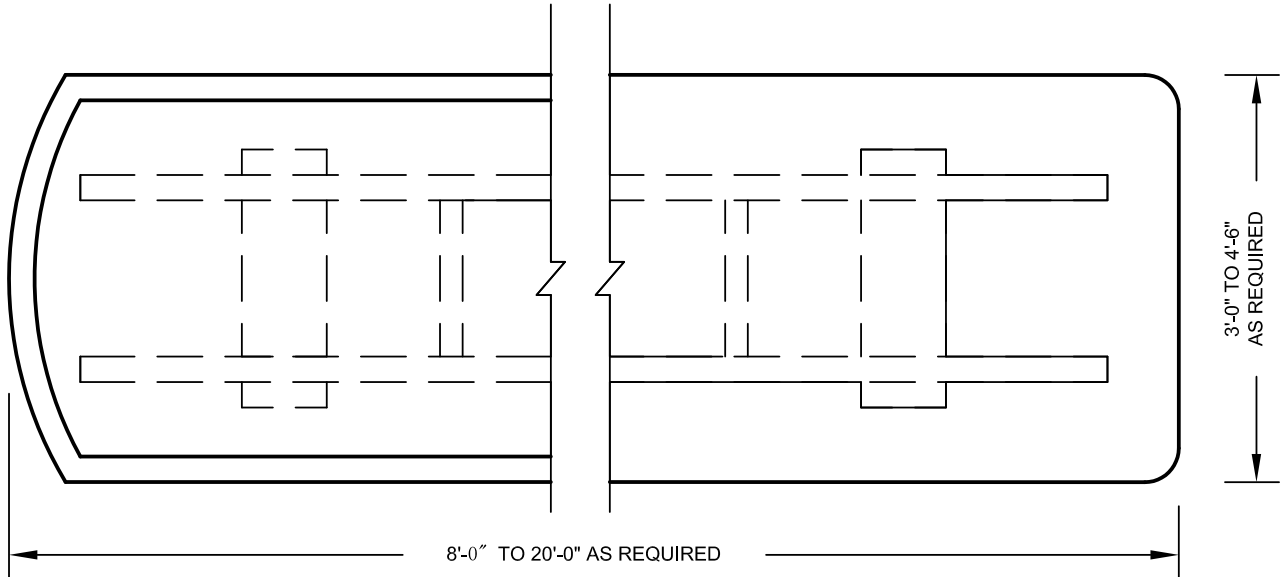

**1** PLAN VIEW  
3/4" = 1'-0"

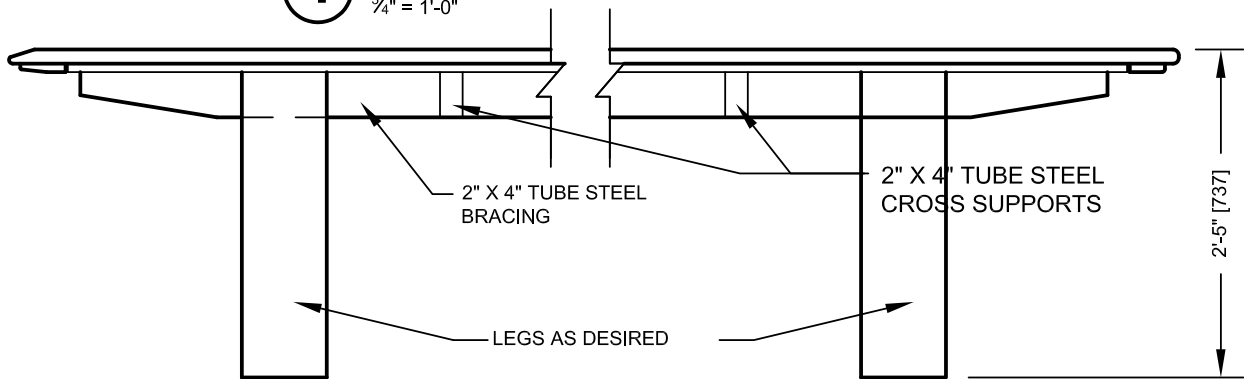

**2** ELEVATION  
3/4" = 1'-0"

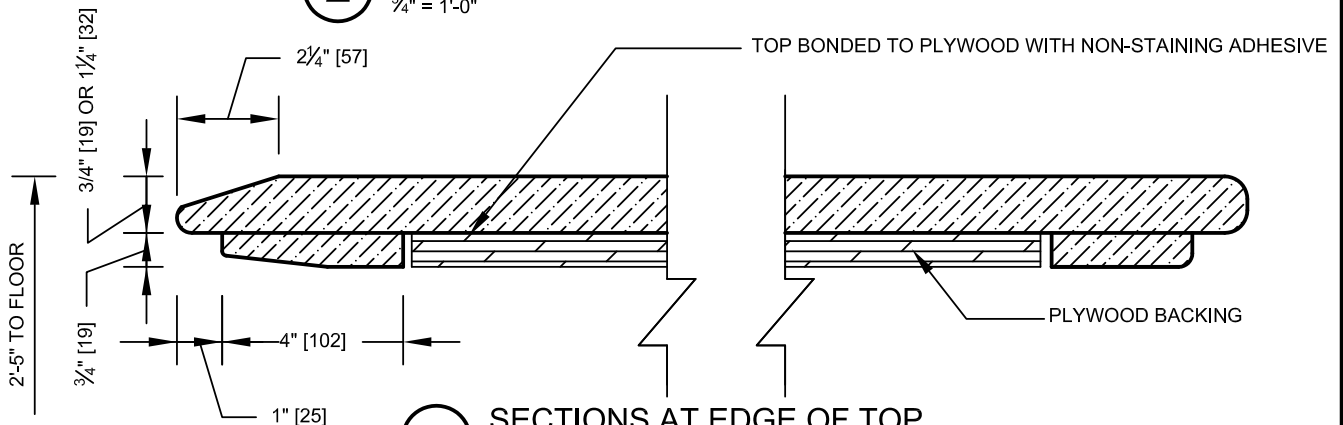

**A** SECTIONS AT EDGE OF TOP  
3" = 1'-0"



MARBLE INSTITUTE of AMERICA  
28901 Clemens Road - Suite 100  
Cleveland, OH 44145  
Tel: (440) 250-9222  
Fax: (440) 250-9223  
www.marble-institute.com

REV	DATE
0	Aug 2006
1	Oct 2006

## STONE CONFERENCE TABLE TOP DETAILS

MIA DIMENSION STONE DESIGN MANUAL VII

DRWG NO: 19-D-1





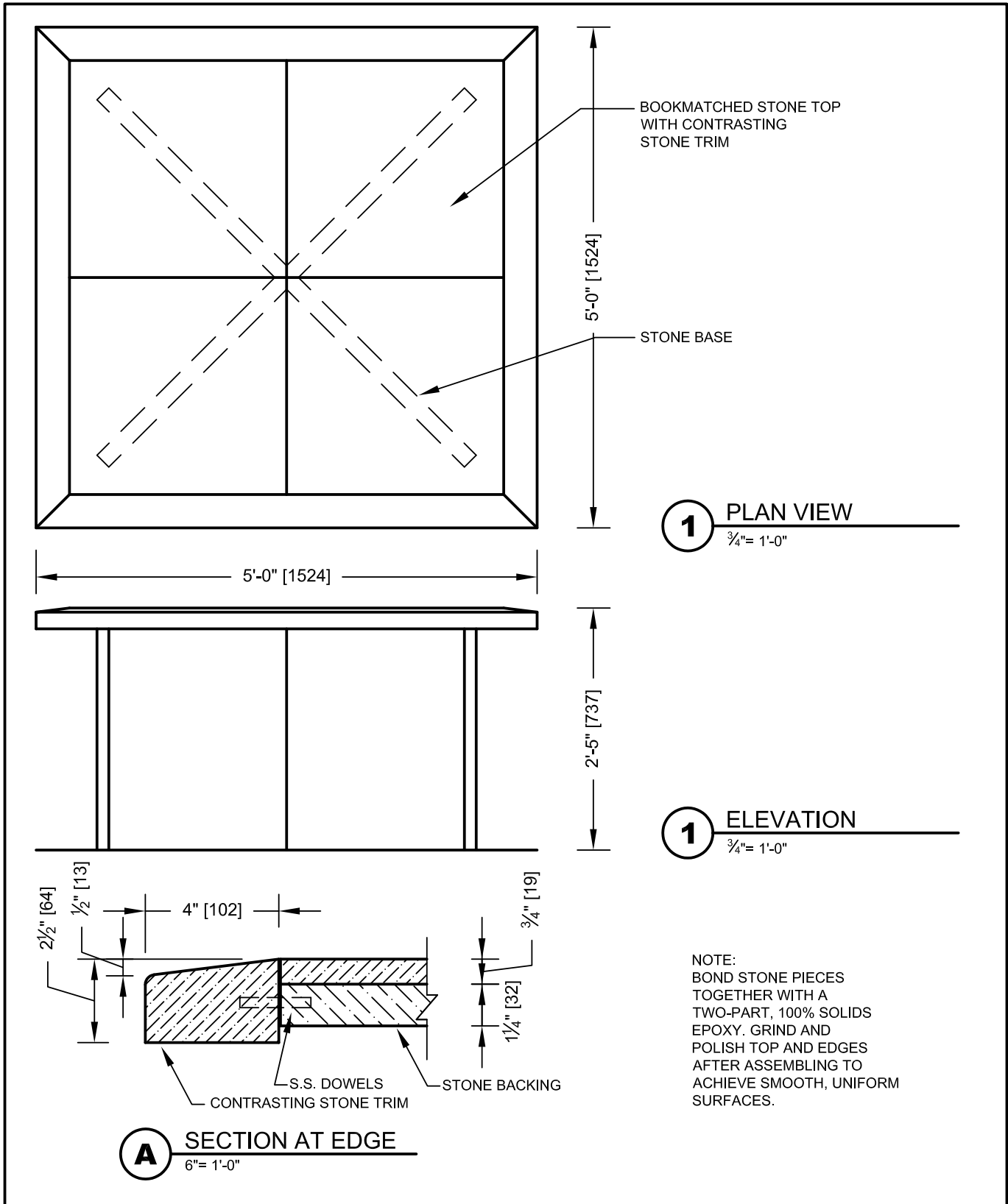

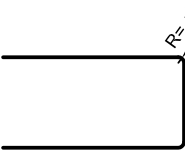
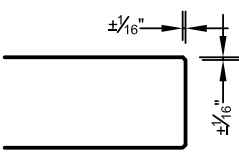
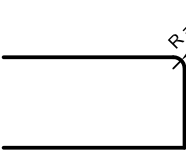
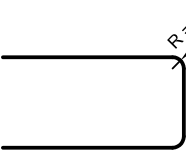
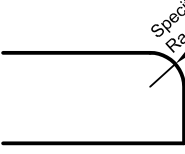
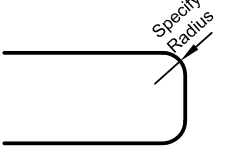
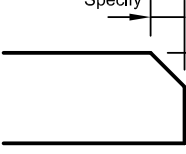
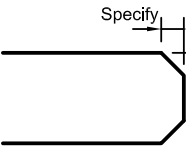
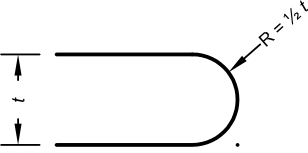
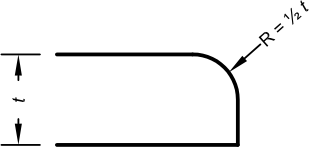
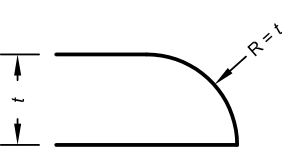

SCALE:  
As Noted

# SUPPLEMENTAL INFORMATION STONE FURNITURE / STONE FURNITURE AND TOPS

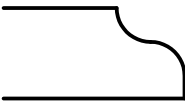

	MARBLE INSTITUTE of AMERICA 28901 Clemens Road - Suite 100 Cleveland, OH 44145 Tel: (440) 250-9222 Fax: (440) 250-9223 www.marble-institute.com	REV 0 1	DATE Aug 2006 Oct 2006	<h2 style="margin: 0;">CONFERENCE TABLE DETAILS</h2> <p style="margin: 0;">MIA DIMENSION STONE DESIGN MANUAL VII</p>
			DRWG NO: 19-D-2	SCALE: As Noted

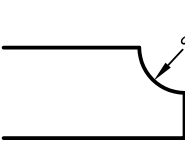
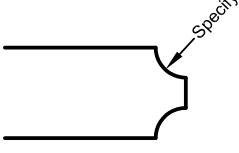
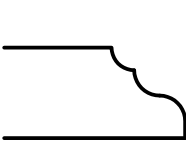
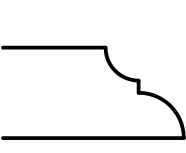
## SUPPLEMENTAL INFORMATION STONE FURNITURE / STONE FURNITURE AND TOPS

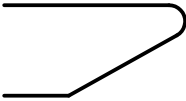
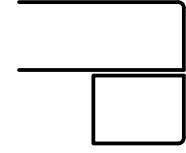
 Straight with Radius Eased Edges (1)	 Straight with Chamfer Eased Edges (1)	 Pencil Round (2)	 Double Pencil Round (2)
 Radius (3)	 Double Radius (3)	 Chamfer (3)	 Double Chamfer (3)
 Full Bullnose	 Half Bullnose	 Demi Bullnose	 Chiseled or "Rocked"
 Ogee	 Ogee Roundover	 Dupont	 Normandy
 Cove (3)	 Double Cove (3)	 Cove Ogee	 Cove Dupont
 Stair Tread	 Waterfall (or Triple Waterfall)	 Platner (or Knife Edge)	 Laminated (4)

**Notes:**

1. The term "Eased Edge" more commonly refers to a slightly radiused profile than a slightly chamfered profile, although the use of the term varies regionally and/or with specific fabricators. In either case, the edge treatment is slight, and normally does not exceed  $\frac{1}{16}$ " (1.5 mm).
2. "Pencil Round" generally refers to a radius near that of a standard pencil, approximately  $\frac{1}{8}$ " to  $\frac{3}{16}$ " (3 to 4 mm).
3. Radius, Chamfer, or Cove edge profile can be any dimension. The actual dimension should be specified at the time of sale. Chamfers are most commonly 45°, although not necessarily so.
4. Many of the profiles shown on this drawing can be done with laminated edge details.

	MARBLE INSTITUTE of AMERICA 28901 Clemens Road - Suite 100 Cleveland, OH 44145 Tel: (440) 250-9222 Fax: (440) 250-9223 www.marble-institute.com	REV 0 1	DATE Aug 2006 Oct 2006	<h3 style="margin: 0;">EDGE PROFILE NOMENCLATURE</h3> <p style="margin: 0;">MIA DIMENSION STONE DESIGN MANUAL</p>	SCALE: N.T.S.
			DRWG NO: 19-D-3		